

GaN ePower Integrated Circuits Applied to Motor Drives

The latest ePower™ integrated circuits based on gallium nitride technology by Efficient Power Conversion are revolutionizing motor drive applications such as industrial drones, e-bikes, scooters, power tools.

By Marco Palma, Director of Motor Drive Systems and Applications at Efficient Power Conversion

Since its introduction, gallium nitride technology has opened a new era in the world of power electronics. The main differences between gallium nitride and silicon technologies are well described in [1] and are summarized in Table 1.

Parameter		Silicon	GaN
Band Gap E_g	eV	1.12	3.39
Critical Field E_{crit}	MV/cm	0.23	3.3
Electron Mobility μ_n	cm ² /V·s	1400	1500

Table 1: Material properties of GaN and Si

The three most important parameters in this comparison are the higher bandgap, critical field, and electron mobility. The critical field, measured in volts per centimeter, determines the threshold for avalanche breakdown. The voltage at which a device breaks down is therefore proportional to the width of the drift region. In the case of GaN, the drift region can be 10 times smaller than in silicon for the same breakdown voltage. When these parameters are all combined, if the critical field of the crystal is 10 times higher, it follows that the electrical terminals can be 10 times closer together. This leads to a clear differentiation factor between GaN and silicon: medium voltage gallium nitride devices can be built on a planar technology while this is cost-prohibitive for silicon devices. To be competitive, silicon devices are made on a vertical technology, usually with gate and source on the top and drain on the bottom, making it physically impossible to have two power devices in the same chip. EPC's GaN-on-Si planar technology does not have this limit of having to be built vertically, and a schematic cross section of an integrated circuit that takes advantage of this is shown in Figure 1.

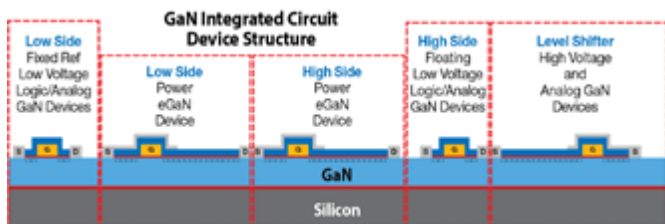

Figure 1: EPC gallium nitride technology enables integration of power devices with gate driver logic

Starting with discrete lateral eGaN® FET devices, EPC quickly moved to higher levels of integration. In 2014, EPC introduced a family of integrated devices comprised of multiple FETs on one chip, which became the starting point for the journey toward a power system-on-a-chip. This trend was expanded with the introduction of the EPC2107 and EPC2108, integrated half bridges with integrated synchronous bootstrap transistors.

In 2018, EPC continued on its integration path with the introduction of GaN ICs combining gate drivers with high-frequency GaN FETs in a single chip for improved efficiency, reduced size, and lower cost. In 2019, the ePower Stage IC family of products redefined power

conversion by integrating all requisite power system-on-a-chip functions in a single GaN-on-Si integrated circuit at higher voltages and higher frequency levels - beyond the reach of silicon. Most recently, in 2021 the EPC23101 in combination with the EPC2302 power stage chipset was introduced to the market.

GaN Integrated Circuit Monolithic Power Stage – EPC2152

The first ePower Stage device was introduced in 2019. The EPC2152 is a monolithically integrated single-chip driver plus GaN FET half-bridge power stage IC. Input logic interface, level shifting, bootstrap charging, and gate drive buffer circuits, along with GaN output FETs configured as a half bridge, are integrated within a monolithic chip. This integration resulted in a chip-scale LGA form factor that measures only 3.85 mm x 2.59 mm x 0.63 mm. The two GaN output FETs in half-bridge topology are designed to have the same 8.5 mΩ typical $R_{DS(on)}$.

Integration of GaN FETs with on-chip gate drive buffers practically eliminates the effects of common source inductance and gate drive loop inductance. Power loop inductance is minimized by the LGA pinouts that facilitate the internal vertical layout technique. The block diagram of EPC2152 is shown in Figure 2 and the reference design, EPC9146 BLDC inverter functional block diagram is given in Figure 3.

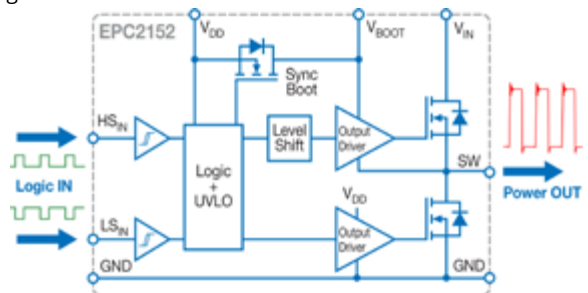

Figure 2: EPC2152 GaN integrated circuit block diagram

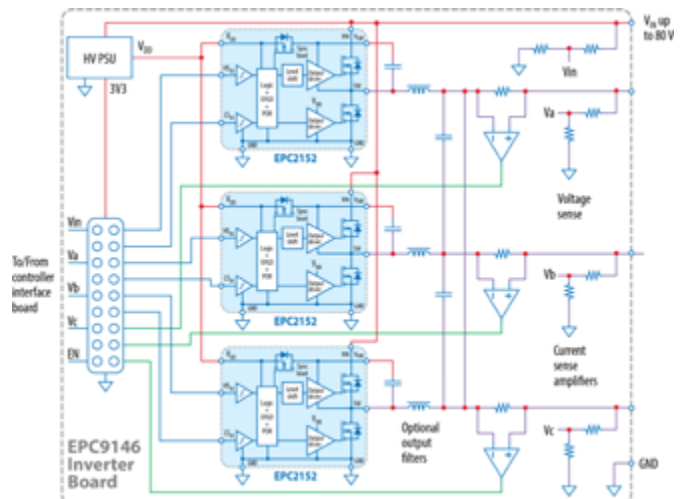

Figure 3: EPC9146 BLDC inverter functional block diagram

Applications with low L/R time constant in the motor

All applications that require high electrical frequency and fast dynamics, such as drone propellers and e-bike in-pedal motors, use very low inductance (single-digit Ω H range) motors. With the advent of more efficient magnetic circuit designs realized by better materials and higher strength permanent magnets, the number of turns on an electromagnetic phase can be reduced and still produce the same back-emf.

Setup	Inverter 20 kHz, 500 ns dead time 400 RPM, 5 A _{RMS}	GaN inverter 100 kHz, 14 ns dead time 400 RPM, 5 A _{RMS}
Input inductance	2.7 μ H	None
Input capacitor	660 μ F electrolytic	44 μ F ceramic
Pin	121.3 W	113.3 W
Pout	119.6 W	111.3 W
$\eta_{inverter}$	98.50%	98.20%
Speed	42.25 rad/s	41.94 rad/s
Torque	1.876 Nm	1.940 Nm
Pmech	79.3 W	81.36 W
η_{motor}	66.30%	73.10%
η total efficiency	65.30%	71.80%

Table 2: Comparison between 20 kHz, 500 ns inverter and 100 kHz, 14 ns GaN inverter with reduced input filter [2]

Permanent magnet brushless motors generate back-emf voltage, e , proportional to speed, ω ($e = K_e \omega$), and the maximum speed a given motor can run is directly related to the DC bus voltage and the voltage constant, K_e . To increase the speed, it is necessary to lower K_e , by reducing the phase coil turns count, which reduces the inductance by the square of the difference. Limiting the current ripple to less than 10% of the phase current is a good design practice and can be only achieved by increasing the PWM frequency.

The current rise with time is related to the ratio of voltage to inductance, and as inductance decreases, the current rises quicker, as does the PWM induced current ripple. The decreased current rise time and larger ripple increases the amount of heat generated and creates additional EMI noise, which is not desirable. In general, these motors have a small time-constant, $\tau = \frac{L}{R}$, that can benefit from a 100 kHz PWM frequency.

Input current and voltage ripple

The input voltage ripple Δv_{in} in an inverter is proportional to the output phase current and inversely proportional to the PWM frequency and input capacitance, as per eq. (1)

$$\Delta v_{in} \propto \frac{1}{f_{PWM}} \frac{I_{phase}}{C_{in}} \quad (1)$$

The desired ripple depends on the EMI constraint given by the emissions generated by the cables from the dc source to the inverter. If the PWM frequency is in the range of 20 kHz, the required input capacitance C_{in} can only be practically obtained by using electrolytic capacitors that are bulky and less reliable than ceramic capacitors. Moreover, the electrolytic capacitors are limited by the RMS current that can flow through them, thus requiring more capacitors in parallel and resulting in a total input capacitance that is higher by more than one order of magnitude than needed for a design. When the frequency is increased to 100 kHz, designers can use ceramic capacitors such as X7R, keeping in mind, as a design rule, the effective capacitance drops to half of the specified value when the applied voltage is half of the rated voltage. The EPC9173 reference design provides for both electrolytic and ceramic capacitors, giving chance for designers to select their preferred switching frequency and to add or remove the capacitors as preferred.

Power tools with trapezoidal modulation

Many power tools applications are still using trapezoidal modulation schemes and related inverter schematics. Usually, these applications are based on three hall sensors to detect the rotor position with a resolution of 60 electrical degrees, and they have a single shunt to measure the current in the DC bus return. The six-step operation has many advantages for BLDC drives, such as maximum power utilization and widened flux-weakening region. However, due to the maximum utilization of inverter output, a saturation of the current regulator makes it difficult to maintain instantaneous current control capability. In most conventional systems it is implemented by voltage angle control with cycle-by-cycle current limit, with unsatisfactory dynamic performance. If the current limit is reached during the PWM cycle, the energizing device (depending on the current direction) is switched off until the next PWM cycle.

The principle of the BLDC motor is to energize the phase pair, which can produce the highest torque. To optimize this effect the back-emf shape is designed to be trapezoidal, but, in reality, it is sinusoidal with some higher harmonics. The combination of a DC current with a trapezoidal back-emf makes it theoretically possible to produce a constant torque. In practice, the current cannot be established instantaneously in a motor phase. As a consequence, the torque ripple is present at each 60-degree phase commutation.

With the current-limiting cycle-by-cycle scheme and low inductance motors, the lower the PWM frequency, the higher the current ripple. This in turn generates heat and unnecessary power dissipation. Using a GaN inverter, with the same trapezoidal scheme, makes it possible to increase the PWM frequency and then reduce the current ripple, obtaining higher efficiency, less heat, and fewer vibrations.

The GaN motor drive reference designs EPC9173 and EPC9167 are equipped with a current comparator circuit whose output can be used by the microcontroller as a signal for cycle-by-cycle current limiting to follow a trapezoidal modulation. With this system, power tools designers can test the reference designs to assess the GaN advantage in their application.

Conclusions

When dealing with motor applications, GaN inverters can increase the efficiency of the system if PWM frequency is increased, the dead time is drastically reduced, and the input capacitance is converted from electrolytic capacitors to ceramic capacitors. Using EPC's new GaN integrated circuits, such as the EPC2152 and EPC23101, results in increased power density and system efficiency, while saving much system design effort.

References

- [1] A. Lidow, M. De Rooij, J. Strydom, D. Reusch, J. Glaser, *GaN Transistors for Efficient Power Conversion*. Third Edition, Wiley. ISBN 978-1-119-59414-7
- [2] A. Lidow, Ed. *GaN Power Devices and Applications*, El Segundo, CA, USA: Power Conversion Publication, 2022.
- [3] M. Palma, S. Musumeci, F. Mandrile and V. Barba, "GaN Devices for Motor Drive Applications," 2021 IEEE 8th Workshop on Wide Bandgap Power Devices and Applications (WiPDA), 7-11 Nov. 2021, Redondo Beach, CA, USA, pp. 146-151.
- [4] D. Cittanti, V. Mallema, F. Mandrile, S. Rubino, R. Bojoi, and A. Boglietti, "PWM-Induced Losses in Electrical Machines: An Impedance-Based Estimation Method," 2021 24th International Conference on Electrical Machines and Systems (ICEMS), November 2021